

"If you know subwoofers, you know about Velodyne."

- Corey Greenberg

Home Theater Technology/February 1995

"It delivered room-shaking bass and dramatically demonstrated the effectiveness of a single subwoofer placed to one side of the room."

- Julian Hirsh

Stereo Review, January 1997

"Notes were distinct, not blurry".

Home Theater, May 2002

Other Velodyne Subwoofer Products:

CHT Series

CHT-8

CHT-10

CHT-12

CHT-15

CHT Front Row System

VX-10

Deco System

Deco System

Deco Satellites

SPL Series

SPL-800

SPL-1000

SPL-1200

SPL-523 Satellites

HGS Series II

HGS-10

HGS-12

HGS-15 THX Ultra 2

HGS-18 THX Ultra 2

Velodyne Acoustics, Inc.

345 Digital Drive

Morgan Hill, CA 95037

408.465-2800 voice

408.779-9227 fax

<http://www.velodyne.com>

Service E-mail: service@velodyne.com

Product E-mail: help@velodyne.com

Technical E-mail: techhelp@velodyne.com



Printed on recycled paper.

63-DLS RevA 18APR03

DLS-3500/DLS-3750/ DLS-4000

Owner's Manual



Velodyne[®]

Audio/Video Subwoofer System



CAUTION
RISK OF ELECTRIC SHOCK
DO NOT OPEN



Caution

To reduce the risk of electric shock, do not remove cover (or back). No user-serviceable parts inside. Refer servicing to qualified service personnel.

The lighting flash with arrowhead symbol is intended to alert the user to the presence of uninsulated "dangerous voltage" within the product's enclosure that may be of sufficient magnitude to constitute a risk of electric shock to persons.

The exclamation point symbol is intended to alert the user to the presence of important operating and maintenance (servicing) instructions in the literature accompanying the subwoofer.

1. Read Instructions -- All safety and operating instructions should be read before the subwoofer is operated.
2. Retain Instructions -- The safety and operating instructions should be retained for future reference.
3. Heed Warnings -- All warnings on the subwoofer and in the operating instructions should be adhered to.
4. Follow Instructions -- All operating and use instructions should be followed.
5. Water and Moisture -- The subwoofer should not be used near water -- for example, near a bathtub, washbowl, kitchen sink, laundry tub, in a wet basement, near a swimming pool or the like.
6. Carts and Stands -- The subwoofer should be used only with a cart or stand recommended by the manufacturer.
7. Wall or Ceiling Mounting -- The subwoofer should be mounted to a wall or ceiling only as recommended by the manufacturer.
8. Ventilation -- The subwoofer should be situated so that its location or position does not interfere with its proper ventilation. For example, the subwoofer should not be situated on a bed, sofa, rug, or similar surface that may block the ventilation openings; or placed in a built-in installation such as a bookcase or cabinet that may impede the flow of air through the ventilation openings.
9. Heat -- The subwoofer should be situated away from heat sources such as radiators, heat registers, stoves, or other subwoofers that produce heat.
10. Power Sources -- The subwoofer should be connected to a power supply only of the type described in the operating instructions or as marked on the subwoofer.
11. Power-Cord Protection -- Power-supply cords should be routed so that they are not likely to be walked on or pinched by items placed upon or against them, paying particular attention to cords at plugs, convenience receptacles, and the point at which they exit from the subwoofer.
12. "Caution: To prevent electrical shock, match wide blade of plug to wide slot, fully inserted." "Attention: Pour éviter les chocs électriques, introduire lame la plus large de la fiche dans la borne correspondante de la prise et pousser jusqu' au fond".
13. Cleaning -- The subwoofer should be cleaned only as recommended by the manufacturer.
14. Nonuse Periods -- The power cord of the subwoofer should be unplugged from the outlet when left unused for a long period of time.
15. Object and Liquid Entry -- Care should be taken so that objects do not fall and liquids are not spilled onto the enclosure.
16. Damage Requiring Service -- The subwoofer should be serviced by qualified service personnel when:
 - a. The power-supply cord or plug has been damaged.
 - b. Objects have fallen or liquid has been spilled into the subwoofer.
 - c. The subwoofer has been exposed to rain.
 - d. The subwoofer does not appear to operate normally or exhibits a marked change in performance.
 - e. The subwoofer has been dropped or damaged.
17. Servicing -- The user should not attempt to service the subwoofer beyond what is described in the operating instructions.

All other servicing should be referred to qualified service personnel.

SPECIFICATIONS	DLS-3500	DLS-3750	DLS-4000
Cabinet (H,W,D)	15" x 12" x 18"	16.25" x 15" x 21"	18" x 15" x 21"
Frequency Response	35Hz-140Hz	28Hz-120Hz	25Hz-120Hz (±3 dB)
High Pass Crossover (6 dB/octave slope)	Passive 85Hz	Passive 85Hz	80Hz or 100Hz
Low Pass Crossover	40Hz -120Hz (12 dB/octave, 24 dB ultimate)		
Amplifier (Class A/B)	350 watts/ 160 watts RMS power	375 watts/ 175 watts RMS power	400 watts/ 200 watts RMS power
Woofers	8" forward firing (6.3" piston diameter)	10" forward firing (8.2" piston diameter)	12" forward firing (9.9" piston diameter)
Magnet	40 oz.	40 oz.	55 oz.
Voice Coil	2" two-layer copper	2" four-layer copper	2" four-layer copper
Inputs	Line-level and speaker-level		
Outputs	Line-level and speaker-level		
Warranty	Two years (parts and labor)		
Weight	44 lbs. (approx.)	53 lbs. (approx.)	60 lbs. (approx.)

Specifications are subject to change without notice.

FOR YOUR RECORDS...

DATE PURCHASED _____

DEALER _____

SERIAL# _____

* NOTE: Please complete and return your warranty card within ten (10) days or

RegisterON-LINE
It's faster...and easier
www.velodyne.com



Troubleshooting and Service

Before seeking service for your subwoofer, please re-check all systems. Following is a simple troubleshooting guide to assist you.

1. Verify unit is plugged in and power outlet used is active.
2. Is power switch on?
3. Is auto turn on/off set properly?
4. Is unit receiving an input signal from your source?
5. Have all controls on subwoofer (volume, crossover, phase, etc.) been properly set?
6. If unit has been running at high levels, one of the protection circuits may be engaged.
7. Has the built-in amplifier overheated?

If the protection circuitry is active, the unit may cycle on and off until operating parameters return to normal. Under more serious conditions, the unit may shut off completely. Normal operation will return upon cooling, but you may be required to turn the power off and then on again to reset the unit.

The following conditions require service by a qualified technician:

1. The power cord has become damaged.
2. The unit does not appear to operate normally or exhibits a marked change in performance.
3. The unit has been exposed to water.
4. Some part of the cabinet or circuitry is physically damaged.

***Thank you for purchasing a
Velodyne DLS Subwoofer!***

Congratulations!

Congratulations on your purchase of a Velodyne DLS subwoofer system. This system represents the state of the art in low frequency reproduction. Your new subwoofer features Velodyne's exclusive DLS (Distortion Limiting System) technology that significantly improves the subwoofer's performance by limiting audible amplifier distortion and controlling the driver excursion. The result is a subwoofer that reproduces music and home-theater with a fraction of the audible distortion found in lesser products. This exclusive DLS technology increases the detail and definition of your subwoofer without sacrificing output or dynamic impact.

Read and follow the instructions below to insure safe and proper system operation.

Warning!

To prevent fire or shock hazard, do not expose this equipment to rain or moisture. To avoid electrical shock, do not open speaker enclosure or amp chassis cover. Please observe all warnings on the equipment itself. There are no user serviceable parts inside. Please refer all service questions to your authorized Velodyne dealer.

Prior to installation

Please unpack the system carefully. Remove all staples used to seal the carton as they can scratch the cabinet. Please save the carton and all packaging materials for future use. Record the serial number in the space provided on the warranty card or log onto www.velodyne.com.

Product Features and Controls

- Built-in 160 watt (RMS) power amplifier (DLS-3500)
- Built-in 175 watt (RMS) power amplifier (DLS-3750)
- Built-in 200 watt (RMS) power amplifier (DLS-4000)
- Distortion Limiting System (DLS) - limits amplifier distortion and controls driver excursion
- Subwoofer Direct - switchable crossover bypass
- Adjustable (40 to 120Hz) low-pass crossover
- Selectable (80 or 100Hz) high-pass crossover (DLS-4000)
- 85 Hz high-pass crossover (DLS-3500/DLS-3750)

continued...



- Line-level inputs and outputs
- Speaker-level inputs and outputs
- Signal sensing auto turn on/off with bypass option
- Variable volume control
- Selectable phase control (0 or 180 degrees)
- Dual staggered low-pass crossover; 12dB/octave initial, 24dB/octave ultimate

Installation

Your new DLS subwoofer system provides for a number of installation options. Read all the installation information below in order to determine which installation option is best for your system. **Remember to perform all installation procedures with system power turned off.**

Inputs

Your new subwoofer is equipped with both speaker-level and line-level inputs. Use the RCA/Phono type "INPUT" jacks when connecting your subwoofer to a pre-amp, signal processor, or line-level crossover. The "SPEAKER LEVEL-INPUT" jacks connect directly to the speaker outputs of a integrated amplifier or receiver. Your amplifier section will notice no additional loading effects when you use these inputs because of their high impedance.

Note:

Do not use both the RCA/Phono "INPUT" connections and "SPEAKER LEVEL-INPUT" connections simultaneously.

Volume control

This control allows you to balance the output from the subwoofer to the main speakers in your system. This control should be set to achieve similar volume level from both the main speakers and subwoofer.

Low-pass crossover

Both sets of inputs sum the left and right channels together and the resulting signal is passed through an adjustable low-pass crossover before being amplified. The crossover control allows you to adjust the upper limit of the subwoofer's frequency response from 40 to 120 Hz. The subwoofer's response will begin rolling off above the frequency you set this control to.

You should set the crossover frequency to obtain a smooth and seamless transition from the subwoofer to the main speakers in your system. If your

Placement

True subwoofers operate at extremely low frequencies which are primarily omni-directional. While it is recommended that the subwoofers be placed on the same plane as the satellite speakers, room and system conditions often dictate otherwise. Keep in mind that frequency response and output level can be **drastically** influenced by placement, depending on the acoustic properties of the listening room. Typically, the optimum location for a subwoofer is tucked away in a corner of your listening room. This location will usually offer the greatest output levels and optimum low frequency extension. The worst location for a subwoofer is typically far away from any walls, and close to the center of your room. Avoid these locations when possible. When using a pair of Velodyne subwoofers in stereo, it is preferable to place each subwoofer by the satellite of the same channel. Typically, a minimum distance of 4 to 5 feet from your TV to the subwoofer will be adequate to avoid any magnetic interference.

Caution!

This subwoofer has electronics built into the cabinet. Do not place the cabinet next to sources of heat such as furnace registers, radiators, etc. Do not place the unit near sources of excessive moisture, such as evaporative coolers, humidifiers, etc. The power cord should be routed in such a way that it will not be walked on, pinched, or compressed in any way that could result in damaging the insulation or wire.

Care of Your DLS Subwoofer

Do not use any harsh detergents or chemicals to clean the cabinet. Abrasives, detergents, or cleaning solutions may damage the finish on the cabinet. We recommend using a damp cloth to clean the cabinet.

During normal conditions, the subwoofer may be left on continuously without any problems. The unit is equipped with a signal sensing circuit that will automatically turn on the unit when a signal is present at the inputs and turn off the unit after several minutes when there is no longer any signal at the inputs.

If you plan to leave the unit unused for an extended period of time, we recommend that you turn off the unit by the master power switch on the rear panel.

continued...



Caution!!!

To avoid damage to your main amplifier, be sure to maintain correct polarity when making all connections. The correct method is to connect red (positive) to red and black (negative) to black. Be sure that all connections are tight, and that there are no loose strands or frayed wires.

Figure 2: Installation using SPEAKER LEVEL INPUTS (from amplifier)

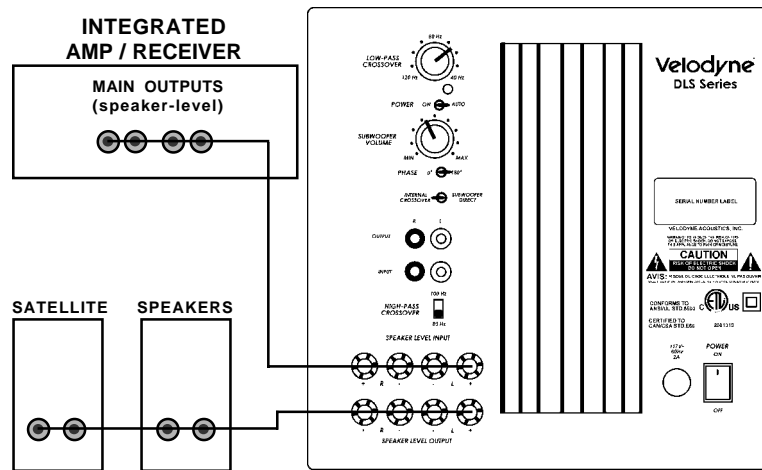

Interconnect Cables

When installing your new DLS subwoofer using the line-level connections, you should always use shielded phono cables. There are many decent cables available today, most any of which will work perfectly well. We do recommend that you keep the length of cable as short as possible to avoid any potential noise problems.

When using speaker level connections, use a decent quality speaker cable that mates well with the connectors. Be very careful to avoid any loose strands or frayed wires which may result in a short, which may damage your equipment. Cables of extremely large size are typically not required. Extremely large gauge wire may not properly fit in the binding posts, resulting in a poor connection and possible short circuits.

main speakers are smaller units with limited low frequency output, you may wish to choose a higher frequency (such as 100-120Hz) than you would with larger speakers which have greater low frequency output. With larger speakers, you might start with this control set lower, such as 80Hz.

Subwoofer Direct

A bypass switch is also provided if you wish to use an external crossover. If you are not using an external crossover, we recommend that you use the one provided within the unit for optimum performance.

Phase adjustment-0°/180°

This control allows you the "reverse" the phase of the subwoofer's output signal 180° to correct for any possible mismatch and resulting cancellation between the subwoofer and your main speakers/amplifier. To adjust, simply listen to the system with music playing. Then move the switch from one position to the other and listen for a change in low frequency output. The correct position will have a greater amount of apparent low frequency output.

Auto turn on function

With this function in the "auto" position, your subwoofer can be safely left with the main power switch on continuously. The subwoofer will turn itself on automatically when an audio signal is present. If no signal is present for approximately 10 minutes, the unit will switch to standby mode. While in standby mode, your subwoofer will draw very minimal power. Leaving the switch in the "on" position can disable this function.

High pass crossover switch

This switch selects the frequency for the high pass crossover. This crossover is functional on both line and speaker-level outputs. Smaller speakers with limited low frequency output may prefer the higher 100Hz setting which will reduce the low frequencies sent to them. Larger speakers with greater low frequency output may be able to handle the 80Hz setting without strain.

Power switch

The master power switch is located on the right half of the unit. This rocker style switch is the main on/off for the unit. This switch should be set to position 1 for on (up), 0 for off (down).

continued...



Line-level Connection

Figure 1 shows connection to a pre-amplifier's main outputs and returning them to your amplifier inputs.

When installed in this fashion, your satellite speakers will be crossed over at 80/100Hz which removes the lower bass from your amplifier and speakers, enabling them to do a better job reproducing high frequencies. By utilizing this method, you will have a bi-amplified system, gaining improved power and headroom for your system.

Figure 1: Installation using line-level (RCA/Phono jack) inputs

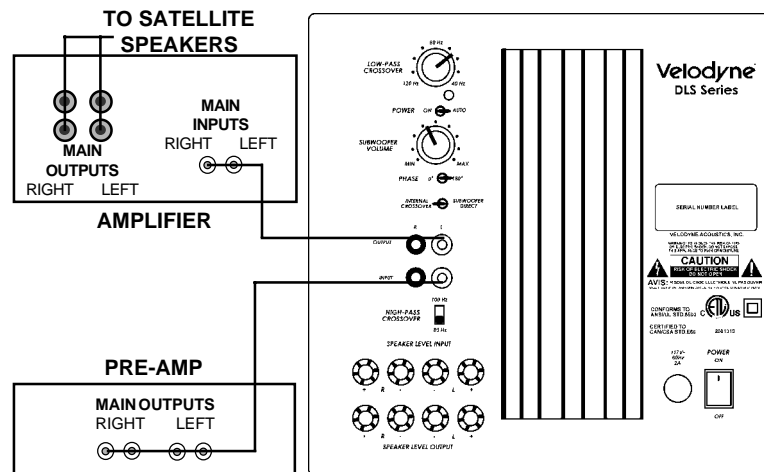

Subwoofer outputs

Your DLS subwoofer is designed to operate using the full range audio signal for input when using the built-in crossover. Many home theater processors/receivers (Dolby Digital, DTS, THX) have a "subwoofer out" jack that is internally filtered and designed to be used with a powered subwoofer.

In these installations, you may bypass the internal crossover in either the processor or your DLS subwoofer. In some installations, it may be beneficial to have a steeper ultimate crossover slope. To do this you can use both your processor's crossover and the one internal to the DLS subwoofer. You should stagger the frequencies (i.e., 120Hz sub, 80Hz processor) for best results.

To bypass the subwoofer's internal crossover when the unit is being fed a low pass signal from another crossover, simply locate the switch marked "SUBWOOFER DIRECT/INTERNAL X-OVER" on the rear panel of the subwoofer and set to the "SUBWOOFER DIRECT" position. This will eliminate the internal crossover from the signal path.

Note . . .

If not using an external crossover, you should use the built-in crossover for optimal performance. When using a single channel input signal (such as a surround sound processor's subwoofer out, or LFE), the auto on/off circuit sensitivity will be affected. When one input channel is used instead of two, the unit will see lower signal levels present at the inputs. This may cause the unit to turn off when listening at low volume levels. If this occurs, simply use a "Y" adapter (available from most dealers) to allow your processor's single sub line to be fed into both L&R inputs. This will make the unit turn on at lower signal levels.

Speaker-level Connection

Figure 2 shows an easy way to connect your DLS subwoofer directly to your receiver or integrated amplifier.

When connected in this fashion, your satellite speakers will be crossed over at 80/100Hz which removes the lower bass from your speakers, enabling them to do a better job reproducing high frequencies.

You may also connect your satellites directly to your receiver or amplifier along with the subwoofer if you wish to bypass the internal high-pass crossover.

continued . . .

